

AcustiColor® Acoustic Tile

Available sizes :

- 1'x 1' | 1'x 2' | 1'x 3' | 1'x 4' | 2'x 2' | 2'x 3' | 2'x 4' | 3'x 3'

Available Thickness :

- .5 in.
- 1 in.
- 1.5 in.

Available finishes :

- Any Sherwin Williams Paint Color

Custom options available:

- Sizes
- Shapes

Manufactured and assembled in the U.S.A.



Acoustical Performance

- Absorption product
- NRC of .55 - .95
- Excellent for mid to high range frequencies absorption



Flammability

- Class A fire rated (ASTM E-84)



Material Composition

- Blend of recycled cotton and cellulose fibers
- Made with 1/10 of the energy required to make traditional fiberglass panels



Health

- Non-toxic
- Non-carcinogenic
- Low emission product



Installation Hardware

- Construction adhesive
- Adhesive tape



AcustiColor® Acoustic Tile

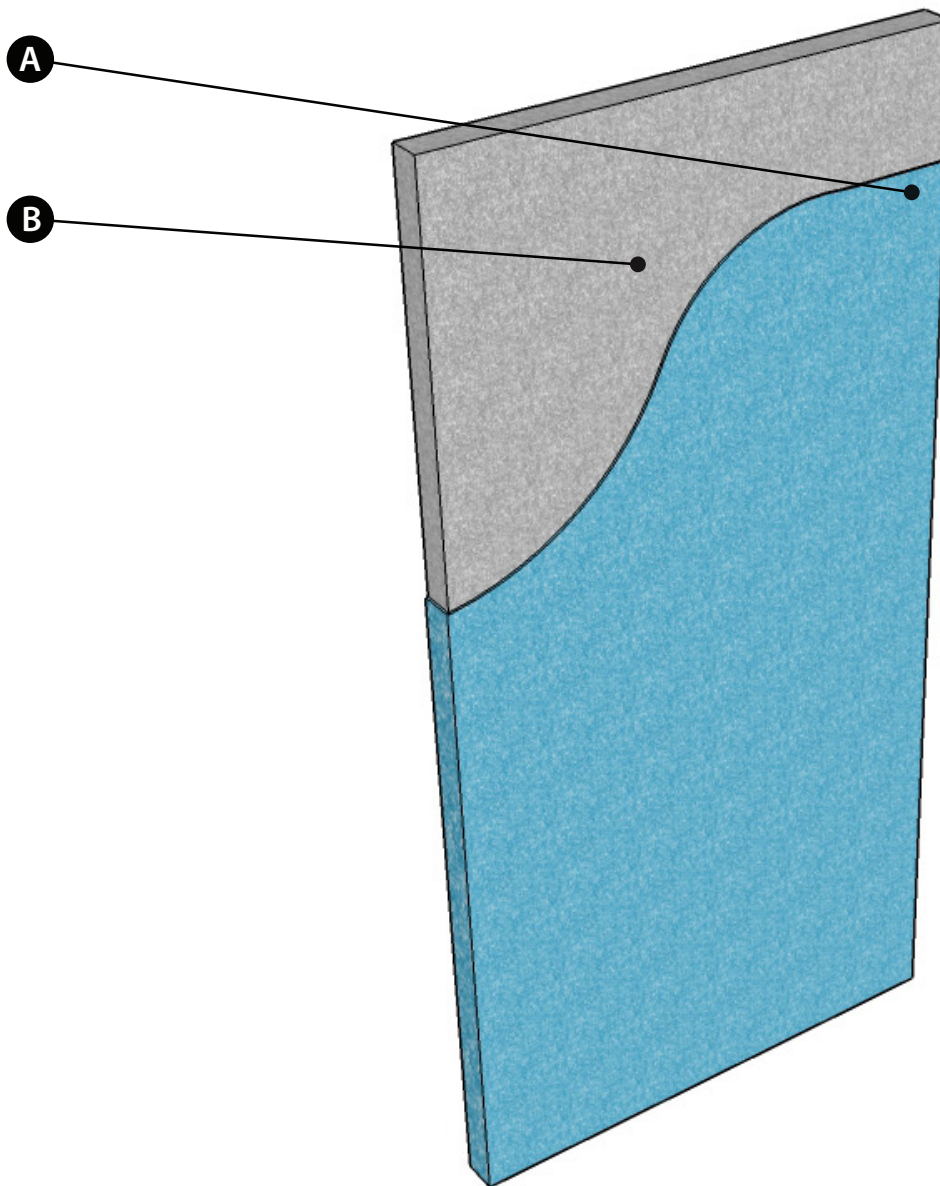

Features:

- A** **AcustiColor®** - Choose any Sherwin Williams color.
- B** **eco-C-tex® Absorption Material** - Composed of non-flammable recycled cotton and cellulose fibers. Does not contain fiberglass.

* all components made and assembled in the U.S.A.